

STOPPER

sistema guidalinee

IT nastro oppure cordone, moderno oppure classico? scegliete ciò che più vi attrae dalla nostra gamma di guidalinee stopper, assicuratevi inoltre ulteriori vantaggi espositivi grazie alla linea di accessori. stopper è la scelta giusta per tutti quelli che sanno dove andare.

personenleitsysteme

DE gurt oder seil, modern oder klassisch? wählen sie aus dem grossen anbot von stopper personenleitsystemen ihre ausführung. mit den stopper accessoires weitere vorteile sichern. stopper ist die richtige entscheidung für alle die wissen wo's lang geht.

crowd control

EN belt or rope, modern or classic? the large assortment of stopper will provide you with the crowd control you are looking for, gain further advantage and ensure efficiency with stopper accessories. stopper: have it your way!



tempaline	tempaflag tempaflag double	tempatree	stopper general information	technical details	stopper eco master point	stopper eco	stopper master
282	286-287	288	290-293	294	297	298	299

overall view eco & master	stopper point	stopper stiletto	print	insert inlay	stopper antipanic	stopper wall	stopper accessories
300-301	302	304	306	307	308	309	310

stopper tex general information	stopper tex alu	stopper tex	stopper tex double	tex cord	tex accessories	stopinfo	maginfo slim
312	313	314	315	316	318	320	322

rondo	cubo
324	325



tempaline

MADE IN EU patent



IT tempaline è il primo sistema guidalinee con base richiudibile. una soluzione semplice, rapida e trasportabile. grazie al design innovativo e brevettato, il piede si apre con un unico movimento della mano e altrettanto facilmente si richiude. i suoi vantaggi sono il basso peso, l'ottima stabilità ed il poco volume d'ingombro per il trasporto e lo stoccaggio. tempaline delinea spazi sia in interno che in esterno, in qualunque luogo dove vi sia la necessità di gestire flussi temporanei di persone.

DE das erste faltbare absper- und personenleitsystem! tempaline ist die lösung für ihr schnelles und mobiles personenleitsystem. dank des patentierten designs wird der fuß einfach aufgespannt und im handumdrehen aufgestellt. genauso schnell und bequem wird tempaline nach dem einsatz abgebaut und verstaut. tempaline punktet durch sein geringes gewicht bei hoher standfestigkeit und geringem volumen für lagerung und transport. tempaline ist die perfekte wahl für laufwege oder absperren im innen- und außenbereich. daneben empfiehlt sich tempaline vor allem auch für temporäre absperren bei reparatur- und instandhaltungsarbeiten.

EN your first foldable crowd control system! tempaline is the perfect choice when you need a fast and mobile queue management system. thanks to its patented design the base simply opens up and is set up in no time at all. just as quickly and conveniently, tempalines folds together after use. tempaline scores with its light weight, high stability and low volume for storage and transport. the guideline system is best for pathways or restricting access areas, both in- and outdoors. tempaline is especially recommended for the temporary use to cordon off areas in instances of maintenance or other works in progress.

B tempaline

1	TPL950SBL	tempaline alu, blue webbing, 1pc
2	TPL950ALSWR	tempaline alu, red/white webbing, 1pc
3	TPL950ALSYB	tempaline alu, black/yellow webbing, 1pc
4	TPLWD950SBL	tempaline wood, blue webbing, 1pc
5	TPL950SWSBL	tempaline black, blue webbing, 1pc
6	TPL950SWSWR	tempaline black, red/white webbing, 1pc
7	TPL950SWSYB	tempaline black, black/yellow webbing, 1pc
8	TPLSET950SBL	set tempaline alu/blue 4pc + bag
9	TPLSET950ALSWR	set tempaline white/red 4pc + bag
10	TPLSET950ALSYB	set tempaline black/yellow 4pc + bag
11	TPQA5H	tempaquick A5 horizontal, 1pc
12	TPQA4H	tempaquick A4 horizontal, 1pc
13	TPQA4V	tempaquick A4 vertikäl, 1pc
14	TPLCAR25	trolley without tempaline, 1pc
15	TPL25ALCBL	trolley with 25 tempaline alu/blue, 1pc
16	TPL25ALCYB	trolley with 25 tempaline white/red, 1pc
17	TPL25ALCWR	trolley with 25 tempaline black/yellow, 1pc

information

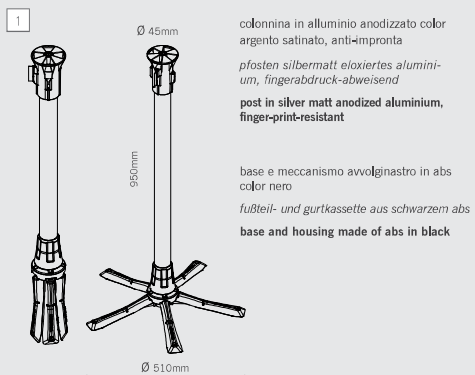

15
 su richiesta possiamo fornire un pratico carrello per il trasporto di massimo 25 tempaline.

auf anfrage bieten wir einen praktischen handwagen, mit dem sich bis zu 25 tempaline bequem transportieren lassen

on request we can supply a practical trolley to carry up to 25 tempaline.

25 pcs

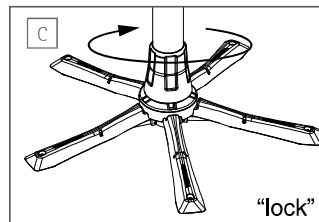
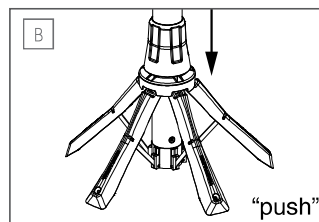
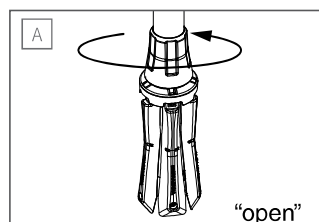

8-10
 borsa per il trasporto imbottita con due manici e cinghia da spalla, color blu. una borsa può contenere 4 colonnine

gepolsterte, trage Tasche mit schultergurt und zwei tragegriffen, in blau, für 4 elemente

padded carry bag with dual handle and carry strap design, in blue, holds 4 posts

4 pcs





11 A5 H
 accessorio portainformazioni bifacciale, per stampe nei formati A5 orizzontale, A4 orizzontale o verticale, materiale acrilico antiriflesso

zweiseitige postertasche zum aufstecken, für einzelblatt info in format A5 horizontal, A4 horizontal oder vertikal, reflektionsarmes acrylglas

double side posterpocket to plug on, for single sheet information in format A5 horizontal, A4 horizontal or vertical, anti-reflective



13 A4 V

attention

la colonna è priva di un sistema frenante che controlli l'avvolgimento automatico del nastro, accompagnarlo manualmente.

keine fliehkraftbremse: führen sie den gurt beim einzug manuell

no integrated brakes controlling the belt retraction speed, guide the webbing with hand



il nastro si estrae facilmente dal meccanismo e si aggancia con semplicità alla colonna successiva

den selbstziehenden gurt einfach aus der kassette ziehen und am nächsten posten in die halterung einschieben.

the retractable belt can be easily pulled out of the housing and is snapped into the adjoining post.



nastro in tessuto antipolvere disponibile in diversi colori
 schmutzabweisendes gurtband in verschiedenen farben
 dirt-repelling webbing in different colors



colonna in faggio smaltato opaco
 posten aus matt lasierter buche
 post in matt glazed beech



nastro in tessuto antipolvere disponibile in diversi colori
 schmutzabweisendes gurtband in verschiedenen farben
 dirt-repelling webbing in different colors

information

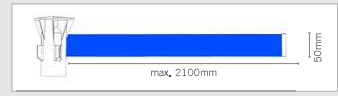



banner not included

tempaflag

MADE IN EU design by KD

IT una bandiera supermobile: l'asta di tempaflag è regolabile e la base può essere chiusa grazie al suo piede speciale, una soluzione perfetta per l'utilizzo mobile. la stoffa viene fissata utilizzando gli orli, il braccio in alto può essere montato orizzontalmente con viti a testa zigrinata, nell'orlo inferiore viene inserito un braccio privo di collegamento con l'asta. tempaflag: la sua bandiera mobile per ambienti interni.

DE flagge ganz mobil: der mast von tempaflag ist stufenlos höhenverstellbar und die basis wird dank des speziellen klappfußes im handumdrehen zusammengeklappt, damit ist tempaflag perfekt für mobilen einsatz, die fahne wird mit saum befestigt, der obere ausleger wird fest montiert und kann mit rändelschrauben horizontal eingestellt werden, im unteren saum wird ein ausleger ohne verbindung zum mast eingelegt. tempaflag: ihre mobile präsentations- und werbefahne für den innenbereich.

EN flag completely mobile: the tempaflag pole is stagelessly adjustable and the base can be easily folded thanks to the special design, the flag is mounted with seam, the upper bar is mounted firmly and can be regulated horizontally with the knurled screws, in the lower seam of the flag one bar is inserted without connection to the pole. tempaflag: your mobile presentation and promotion flag for indoor.

advantages

- ✓ montaggio facile, rapido e senza attrezzi
einfach und schnell ohne werkzeug aufgestellt
quick and easy set up without tools
- ✓ semplice cambio della bandiera, peso ridotto
schneller fahnen-austausch und geringes gewicht
quick exchange of flag and light weight
- ✓ regolabile in altezza senza livelli
stufenlos höhenverstellbar
stagelessly adjustable in height

information

asta e bracci in alluminio anodizzato color argento, base e chiusura dell'asta in abs nero

mast und ausleger aluminium silbermatt eloxiert, basis und mastabschluss schwarzes abs

pole and bar in silver anodized aluminium, base and pole top black abs

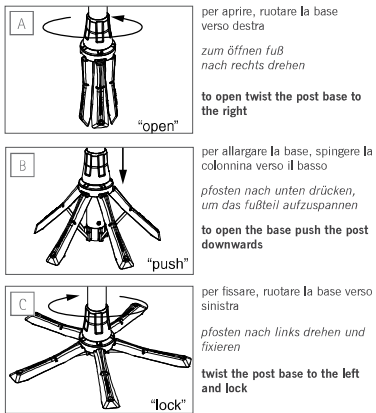
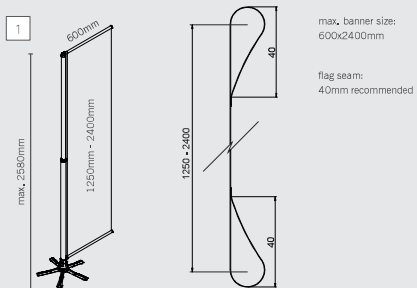

B tempaflag

1 TPF2580AR tempaflag, 1pc



banner not included

tempaflag double

MADE IN EU design by KD

IT la bandiera è doppia! questa variante estesa di tempaflag è semplice da montare e smontare e perfetta per l'utilizzo indoor esattamente come la versione base. i bracci superiori sono fissati stabilmente e possono essere applicati con viti a testa zigrinata, nell'orlo inferiore viene fatto scorrere un braccio privo di collegamento con l'asta.

DE doppelt flagge zeigen: die erweiterte version von tempaflag ist genauso schnell auf- und abgebaut und daher perfekt für ihren einsatz im innenbereich, die oberen ausleger sind fest montiert und können mit rändelschrauben horizontal eingestellt werden, im unteren saum wird ein ausleger ohne verbindung zum mast eingelegt.

EN fly the double flag: the upgraded version of tempaflag is set up as well in no time at all and thus perfect for all applications indoor. the upper bars are mounted firmly and can be regulated horizontally with the knurled screws, in the lower seam of the flag one bar is inserted without connection to the pole.



information

asta e bracci in alluminio anodizzato color argento, base e chiusura dell'asta in abs nero

mast und ausleger aluminium silbermatt eloxiert, basis und mastabschluss schwarzes abs

pole and bar in silver anodized aluminium, base and pole top black abs

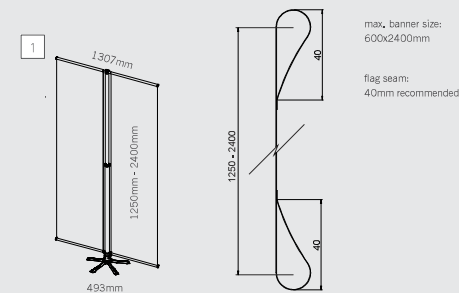

B tempaflag double

1 TPF2580AR tempaflag double, 1pc



tempatree

MADE IN EU patent



IT flessibile e intelligente, tempatree rappresenta una novità assoluta grazie alla base a chiusura e al sistema telescopico per regolare l'altezza dell'asta. un appendiabiti rivoluzionario perché facile da trasportare, di semplice stoccaggio e a chiusura veloce. i quattro ganci appendiabiti si aprono quando il capo viene appeso e si richiudono automaticamente quando viene ritirato. L'asta ad altezza regolabile rende tempatree particolarmente adatto ai bambini. il sistema a chiusura è pensato per facilitare l'utilizzo in fiera, nel corso di eventi e in tutti gli ambienti di ufficio ad attività in progress.

DE flexibel und clever: der hochwertige garderobenständer tempatree punktet mit seinem verschließbaren Klappfuß und der höhenverstellbaren Teleskopstange. der innovative Kleiderständer kann dadurch im handumdrehen kompakt zusammengefasst, leicht transportiert und platzsparend verstaut werden. er ist besonders kinderfreundlich dank der teleskopstange, mit welcher der flexible alu-kleiderständer an die gewünschte höhe angepasst werden kann. die vier garderobenhaken öffnen sich nur, wenn das kleidungsstück aufgehängt ist. das alles macht tempatree ideal für messen und veranstaltungen sowie für alle weiteren flexiblen office-ambiente.

EN flexible and clever: the high quality garment rack tempatree is a great innovation thanks to its foldable base and the telescopic adjustable bar, the revolutionary stand can therefore be folded together in no time, is easy to transport and store. the telescopic bar makes it child-friendly, too: just adjust the flexible aluminium hanger to the desired height. the four hooks open up only when you hang the cloth. this makes tempatree the perfect clothes stand for trade fairs and events and all other flexible office ambiances.



incl. borsa per il trasporto
inkl. transporttasche
incl. transport bag

B tempatree

1 TPT1920AR

tempatree, 1pc

information

colonnina e ganci in alluminio anodizzato color argento, base e adattatore ganci in abs nero, 4 ganci appendiabiti con 2 intagli, chiusura a vite in ottone, cromato

pfosten und haken aluminium silbermatt eloxiert, fußtteil und hakenadapter aus schwarzem abs, 4 garderobenhaken mit jeweils 2 kerben, drehverschluss messing, silbermatt verchromt

silver anodized aluminium post and hangers, black abs base and hooks adapter, 4 coat hooks with 2 notches, brass screw cap, chrome-plated.

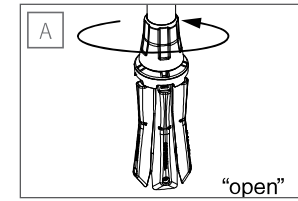
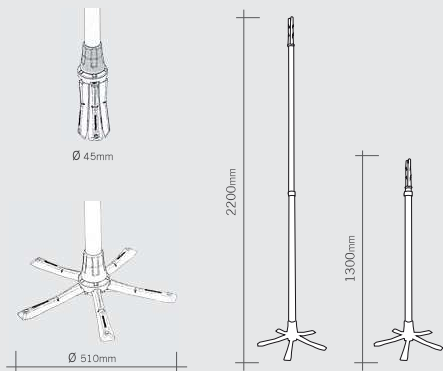

per aprire, ruotare la base verso destra
zum öffnen fuß nach rechts drehen
to open twist the post base to the right

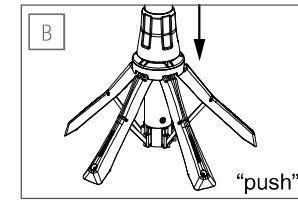

per allargare la base, spingere la colonna verso il basso
pfosten nach unten drücken, um das fußtteil aufzuspannen
to open the base push the post downwards

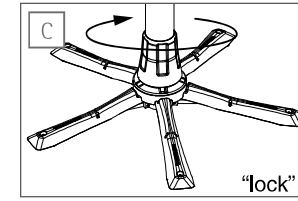

per fissare, ruotare la base verso sinistra
pfosten nach links drehen und fixieren
twist the post base to the left and lock

advantages

- ✓ montaggio senza attrezzi
einfach und schnell ohne werkzeug aufgestellt
quick and easy mounting without tools
- ✓ altezza regolabile
stufenlos höhenverstellbar
height-adjustable
- ✓ base e ganci a chiusura
faltbare basis und hänger
foldable base and hooks
- ✓ peso ridotto e alta stabilità
geringes gewicht und stabiler stand
low weight and high stability



la chiusura a vite consente il facile regolamento dell'asta telescopica
gerippter drehverschluss für einfaches verstellen der teleskopstange
ribbed twist off cap for easy adjustment of the telescopic bar

Stopper® stand in line with italian design

MADE IN EU design by KD



IT stopper è il sistema guidafilee eliminacode sviluppato e prodotto da kunstdünger che sta ricevendo ampi consensi dalla clientela mondiale. ovunque ci siano da dirigere dei flussi di persone, stopper entra in azione: aeroporti, stazioni, centri commerciali, teatri, cinema, musei, stadi e durante manifestazioni culturali e sportive, ma anche in posta, in banca, presso le assicurazioni e in tutti gli uffici pubblici. in questi casi stopper assume due funzioni: direzione e sicurezza. strutturate e dirigate il flusso di persone in attesa garantendone allo stesso tempo il diritto alla privacy, come per esempio succede agli sportelli. inoltre potete impedire l'accesso a luoghi interdetti al pubblico. la già vasta gamma viene ampliata continuamente. con il presente catalogo siamo in grado di fornirvi oltre 4500 possibilità di combinazioni standard, a vostra scelta, grazie ai materiali insoliti, ai nuovi colori e alla personalizzazione del nastro e della base con la stampa digitale. siamo inoltre volentieri a disposizione per ulteriori consigli e suggerimenti.

DE stopper das personenleitsystem von kunstdünger entwickelt und produziert, überzeugt kunden weltweit. wo immer menschen zusammenkommen ist stopper im einsatz: flughäfen, bahnhöfe, kaufhäuser, theater, kinos, museen, stadien, messen, kultur- oder sportveranstaltungen, sowie natürlich bei post, bank, versicherungen und behörden aller art. dabei übernimmt stopper zwei aufgaben: leiten und sichern. strukturieren und führen sie die wartenden und sichern sie zugleich privatsphäre z.b. am schalter, verhindern sie ausserdem unbefugtes betreten von nicht-öffentlichen bereichen. das sortiment wird von uns ständig weiterentwickelt. dieser katalog hat über 4500 mögliche standard-kombinationen für sie zur auswahl. ungewöhnliche materialien, neue farben oder die personalisierung von gurt und basis mit digitaldruck sind kein problem. fragen sie uns, wir beraten sie gerne.

EN customers worldwide choose stopper the crowd control system developed and produced by kunstdünger. wherever people come together, stopper is used: airports, railway stations, department stores, theaters, cinemas, museums, stadiums, fairs, cultural or sporting events as well as post offices, banks, insurers and offices of public authorities. on the job stopper serves two purposes: guiding and safeguarding. with stopper you guide and control the queue and guarantee privacy at the counter as well. furthermore stopper helps you to prevent trespassing into private areas. we continuously enhance the assortment. this catalogue offers you more than 4500 possible standard combinations to choose from. exceptional materials, new colours or customizing of webbings and bases with digital printing is no problem. we are looking forward to your particular request.



stopper



applications

MADE IN EU design by KD

Stopperi®

solo vantaggi!

IT guidare le persone con stopper significa risparmio di spazio, guadagno di tempo e riduzione di stress, clientela e personale sono chiaramente più rilassati, gli spazi vengono usati in modo ottimale e le procedure si snelliscono.

nur vorteile!

DE menschen leiten mit stopper heisst platz sparen, zeit gewinnen und stress vermindern, wartende, wie personal sind deutlich relaxter, räume werden optimal genutzt und abläufe flüssiger.

only advantages!

EN guide persons with stopper means save space, win time and reduce stress, queuers and staff are definitely relaxter, premises are used better and the work flows gets smoother.

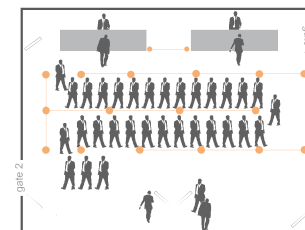
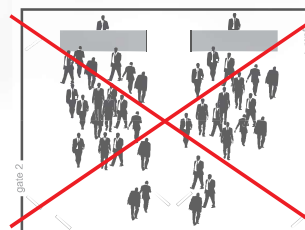



technical details

MADE IN EU design by KD

IT il meccanismo avvolginastro: in abs infrangibile, si monta senza l'utilizzo di viti o colle, mentre senza bisogno di ulteriori utensili il raccordo a 4 direzioni rende possibile l'aggiunta di altri stopper, tutte le parti visibili del raccordo e degli agganci sono senza spigoli, con forme rotondeggianti: per evitare ogni possibile ferita o danno agli abiti, il meccanismo avvolginastro in abs viene inserito nel tubo grazie alle scanalature laterali e al sistema autobloccante, per cambiare il meccanismo basta sganciare le molle grazie ai bottoncini laterali ed estrarlo.

DE die gurtkassette: aus bruchsicherem abs ohne schrauben und klebstoff montiert, an das 4-wege-gehäuse können sie weitere stopper anschließen ohne zusätzliche adapter, alle hervorstehenden teile und sichtbaren kanten sind gerundet: keine verletzungsfahr, kleidung kommt nicht zu schaden, das abs-gurtgehäuse wird in den pfosten eingeschoben und rastet sicher ein, zum austausch die verschlussfeder einfach per knopfdruck öffnen und gehäuse herausziehen.

EN the housing: made of breakproof abs plastics mounted ungummed and without screws, connect more stoppers to the 4-way housing without further adaptor necessary, all jutting parts and edges are rounded: no risk of injury, no damage to clothing, the housing made of abs plastics is simply inserted into the post and locks in safely, for changing just press the button to open and pull out the housing.

il cambio del meccanismo con nastro è possibile in ogni momento, a prova di manomissioni grazie al bottoncino di sicurezza nella parte inferiore del gancio.

austausch der gurtkassetten jederzeit ganz einfach möglich, manipulationsgeschützt dank sicherungsknopf.

quick and easy exchange of the housings at anytime, tamper-proof thanks to the security button.

estensione totale: nastro di 3 mt di lunghezza
vollauszug mit 3m gurtlänge
complete extension of webbing to 3m in length

fissaggio sicuro grazie all'inserimento del gancio nella scanalatura, il bottoncino inferiore rende impossibile lo sganciamento accidentale del nastro.

sichere befestigung durch einschubhalterung mit einrast-sicherung, sicherungsknopf schützt vor ungewolltem lösen der gurte.

fasten securely the webbing by inserting it to the housing, security button prevents accidental opening.



information



A filetto per accessori: foro filettato M8 per tutti gli accessori.
das gewinde: integriertes M8 gewinde für alle accessoire.
thread for accessories: integrated M8 thread for all accessories.

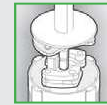

B il sistema frenante: integrato nel meccanismo, il freno regola la sua azione frenante in base alla velocità di rotazione dell'avvolginastro, il nastro viene riavvolto con la stessa velocità dall'inizio alla fine, si evitano così ferite alle mani e alle dita a causa di un riavvolgimento incontrollato e troppo veloce.

die bremse: die eingebaute fliehkraftbremse passt ihre bremsstärke an die rotationsgeschwindigkeit des mechanismus an, das gurtband wird von anfang bis ende mit gleicher geschwindigkeit eingezogen, keine hand- und fingerverletzungen durch unkontrollierte ausschläge des bandes beim einzug.

the brake: the integrated brake adjusts its force according to the rotation speed of the mechanism, the tape is pulled back with the same speed over the full length, no sudden punches of the tape and no risk to injure hand or fingers.

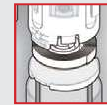

C la molla: appositamente per lo stopper abbiamo realizzato una speciale molla piatta in acciaio, con gli angoli arrotondati, il suo effetto si svolge linearmente su tutta la lunghezza del nastro, ciò significa che le colonnine rimangono stabili anche quando il nastro viene utilizzato per tutta la sua lunghezza e che il nastro stesso rimane perfettamente in tensione anche se usato solo per parte della sua lunghezza, con stopper avete la possibilità di utilizzare l'intera lunghezza di 3m in modo ottimale.

die feder: eigens für stopper haben wir eine stahl-flachfeder mit abgerundeten kanten entwickelt, ihre federwirkung verläuft linear, der zug auf den gurt wirkt immer gleichmässig, das heisst für sie: kein umfallen der pfosten durch zu starken zug bei vollauszug und ausreichende spannung auch bei geringem gurtauszug, mit stopper nutzen sie die gesamte gurtlänge von 3m optimal.

the spring: especially for stopper we designed a steel flat spring with linear resilience, the tape is under a constant tension, that means no toppling of the posts when the tape is completely moved out and enough tension even with little pullout to keep the tape straight, with stopper you use the full tape length of 3m.

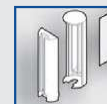

D il gancio di sicurezza: ogni nastro stopper è dotato di uno speciale gancio con una chiusura di sicurezza, il gancio si incastra sul raccordo del meccanismo ed impedisce che il nastro si stacchi inavvertitamente, per aprirlo basta premere leggermente il bottoncino, tale chiusura è standard in tutti i nastri disponibili, nelle prossime pagine troverete ulteriori vantaggi che vi offre il sistema stopper.

der verschluss: jedes gurtband hat einen verschluss mit sicherung, diese sicherung rastet ein und verhindert unbeabsichtigtes auslösen oder herausgleiten, zum öffnen genügt ein knopfdruck, diese sicherung ist standard bei allen gurtausführungen, noch mehr vorteile des stoppersystems finden sie auf den nächsten seiten.

the locking: every tape has a tamper-proof locking, this locking snaps in and prevents from unintended opening or sliding out, to open just press the button, this locking comes with all tape ends as a standard, find more stopper advantages on the following pages.

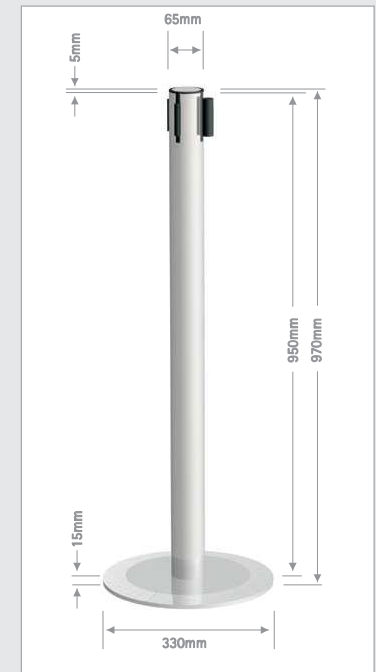
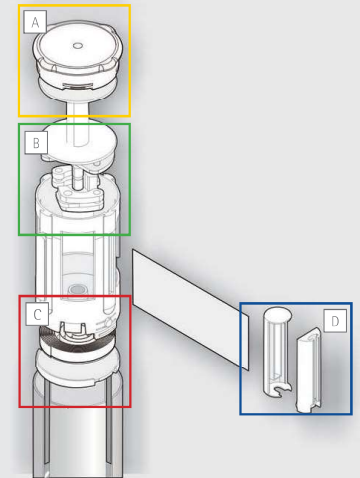



information

master

MADE IN EU design by KD

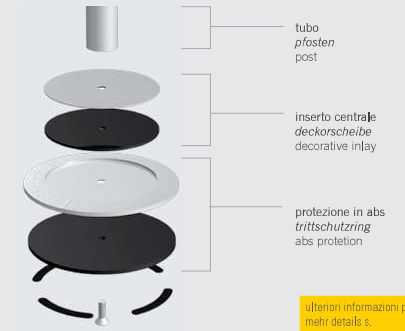
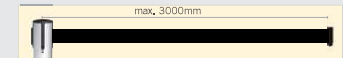
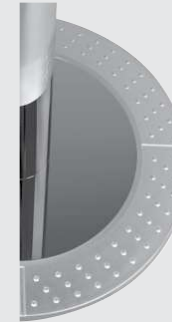

ulteriori informazioni pag. mehr details s. more information p.

299

eco

MADE IN EU design by KD

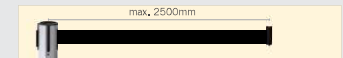

ulteriori informazioni pag. mehr details s. more information p.

298

point

MADE IN EU design by KD

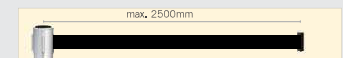

ulteriori informazioni pag. mehr details s. more information p.

302



Stopper® eco

MADE IN EU design by KD

IT più leggera ed anche più economica è la variante minimalista della base stopper: disco in acciaio e copertura abs in diversi colori, combinabili con tutti i tubi e i nastri stopper. a causa della diminuzione del peso, la lunghezza del nastro è di massimo 2,5m.

DE leichter und günstiger präsentiert sich die ökonomische und schlanke variante der stopperbasis: stahlplatte und abs-abdeckung in diversen farben kombinierbar mit allen stopper pfosten und gurten. aufgrund des verringerten gewichts ist der gurtzug auf 2,5m limitiert.

EN lighter and more economic is the leaner version of the stopper base: steel weight plate with abs cover in different colours combinable with all stopper posts and webbings. due to the reduced weight the webbing pull out is limited to 2,5m.

a scelta libera
ihre freie auswahl
your free choice

300-
301

max. 2500mm



Stopper® master

MADE IN EU design by KD

IT molteplicità d'uso, flessibilità e sicurezza: tutto questo è il sistema modulare e componibile stopper. la base è composta da un rivestimento esterno e di protezione in abs, da piastre in acciaio per dare stabilità al sistema e da inserti centrali decorativi in diverse finiture. il punto forte e la novità assoluta sono gli inserti centrali in vetro: facili e veloci da personalizzare grazie alla stampa digitale!

DE vielfalt, flexibilität, sicherheit: das modulare stopper-system, die basis besteht aus einem abs-trittschutz-ring, stahlplatten für sicheren stand und dekorscheiben in diversen ausführungen. der besondere clou sind die dekorscheiben aus sicherheitsglas: mit digitaldruck schnell personalisiert!

EN variety, flexibility, security: the modular stopper-system. the base is composed by a step-on protection ring made of abs plastics, steel-plates for firm standing and decorative plates in different versions. exceptional are the decorative plates made of tempered glass: with digital printing easily customised!

a scelta libera
ihre freie auswahl
your free choice

300-
301

max. 3000mm

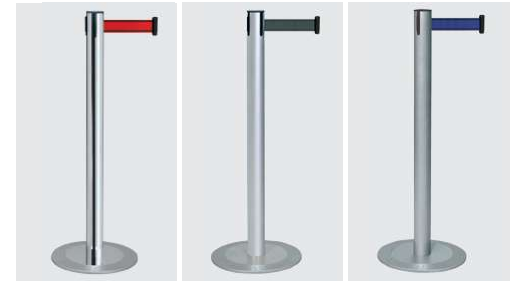



overall view *Stopper* eco & master

a scelta libera

ihre freie auswahl

your free choice

IT più di 4.500 possibilità per creare il vostro stopper preferito! componete il vostro stopper. A meccanismo avvolginastro + B tubo per la base master + C inserto centrale + D protezione in abs o E per la base eco / la base in vetro.

DE mehr als ungläubliche 4.500 möglichkeiten für ihr ganz persönliches stoppersystem! kombinieren sie: A gurtmechanismus + B pfosten und für die master basis C dekorscheibe + D trittschutzing oder E für die eco basis bzw. die glasbasis.

EN more than 4,500 incredible ways to create your favoured stopper guideline system! just choose your combination: A housing + B post and for the master base C insert + D protection or E for eco base resp. the glass base.

PER COMBINARE | ZU KOMBINIEREN | TO COMBINE



+

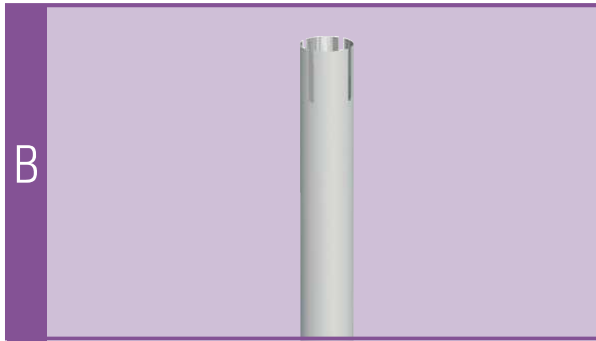

+

or

+

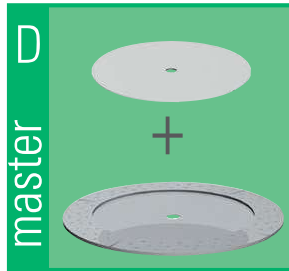
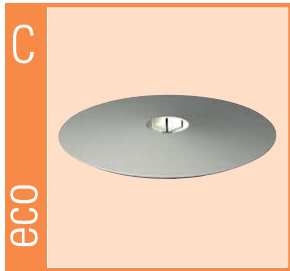

A

base basis base	
STE330SZ	STE330VE
nero/schwarz/black	vetro/glas/glass
STE330LG	STE330CM
grigio chiaro /lichtgrau/light grey	cromo/chrom/chrome

eco base:
a causa della diminuzione del peso, lunghezza del nastro max. 2,5m
aufgrund des geringeren gewichts gurtauszug max. 2,5m
due to the reduced weight webbing pullout is max. 2,5m

A

meccanismo blu + nastro | gehäuse blau + gurt | housing blue + webbing

STGN12065BSW



nero/schwarz/black

STGN12065BBL



blu/blau/blue

il prezzo comprende: meccanismo avvolginastro + nastro | die preise beinhalten gehäuse + gurt | the price comprehensive housing + webbing

A

meccanismo nero + nastro | gehäuse schwarz + gurt | housing black + webbing

STGN12065SSW



nero/schwarz/black

STGN12065SRT



rosso/rot/red

STGN12065SBL



blu/blau/blue

STGH12065YB

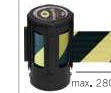

yellow/black

STGH12065WR



red/white

il prezzo comprende: meccanismo avvolginastro + nastro | die preise beinhalten gehäuse + gurt | the price comprehensive housing + webbing

tubo | pfosten | post

B

ST980AR



argento/silber/silver

ST980AL



alluminio/aluminium

ST980CM



cromo/chrom/chrome

ST980SW



nero/schwarz/black

ST980PC*



transparent polycarbonate

ST980YE



giallo/gelb/yellow

ST980RS



rosso/rot/red

D

base | basis | base

inserto centrale | dekorscheibe | decorative inlay

STKINSAR



argento/silber/silver

STKINSAL



alluminio/aluminium

STKINSCM



cromo/chrom/chrome

STKINSSW



nero/schwarz/black

STKINSVE



vetro/glas/glass



protezione in abs | trittschutzing | abs protection

STKABSAR



argento/silber/silver

STKABSGM



grigio metallizzato/grau metallic/grey metallic

STKABSSW

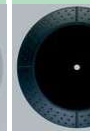

nero/schwarz/black

STKABRS



rosso/rot/red

* fino ad esaurimento scorta | solange vorrat reicht | while stock last





Stopper point

MADE IN EU design by KD

IT stopper point colpisce ed attira l'attenzione grazie alla sua forma moderna e sportiva. il design senza tempo del tubo e della base regalano a stopper point un'apparenza generale di eleganza e sobrietà. stopper point è la soluzione universale, ma comunque di bell'aspetto, per tutte le esigenze di delimitazione di flussi di persone, e proprio nelle peggiori condizioni di utilizzo, il nastro stopper resistente alle grinze mostra maggiormente i suoi vantaggi. disponibile solo in set completo nelle combinazioni alu o nero.

DE stopper point besticht durch moderne, sportive formgebung. zeitloses design von pfosten und basis zeigt ein einheitliches und elegantes gesamtbild. stopper point ist die universelle und doch optisch gefällige absperrlösung für die unterschiedlichsten ansprüche. gerade bei hoher belastung zeigt das knitter-resistente gurtband seine vorzüge. erhältlich nur als kompletset in kombination alu oder schwarz.

EN stopper point wins everyone over because of its modern and sports casual design. the timeless shape of the post and base gives stopper point a consistent yet elegant look. stopper point is the universal choice for different requirements. especially under high impact the crease resistant webbing has its advantages. available only as complete set in the combination black or alu.

information

nastro: resistente alle grinze
gurtband: anti knitter
webbing: anti-crease

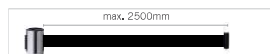

A stopper point

1	SCPALARGSW	point alu with black ribbon, 1pc
2	SCPSSWSSW	point black with black ribbon 1pc



meccanismo grigio chiaro, nastro nero-grigio, tubo in alluminio anodizzato e base in argento satinato.

lichtgraue kassette, schwarz-grauer gurt, eloxiertes alu und kunststoff basis in silbermatt.

light grey housing, black-grey webbing, anodized aluminium and synthetic base in matt silver

meccanismo nero, nastro nero-grigio, tubo e base in nero satinato.

schwarze kassette, schwarz-grauer gurt, pfosten und basis in schwarz matt.

black housing, black-grey webbing, post and synthetic base in matt black



stopper





antipánico: in caso di forte impatto la clip si sgancia in automatico
 anti-panic: bei starkem impact löst sich der clip von selbst
 anti-panic: in case of strong impact the clip will open automatically

information

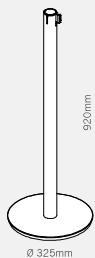

alluminio anodizzato color argento, meccanismo nero, nastro in poliestere repellente allo sporco e ingualciabile, base in metallo RAL 9006 alluminio bianco con copertura in alluminio anodizzato color argento

silbermatt eloxiertes aluminium, gurtkassette schwarz, gurt schmutzabweisendes und knitterfreies polyester, bodenplatte metall RAL 9006 weissaluminium mit abdeckung in silbermatt eloxiertem aluminium

silvermatt anodized aluminium, housing for webbing in black, webbing dirt-repellent, crease-resistant polyester, base made of metal in RAL 9006 white aluminium with a cover in silvermatt anodized aluminium

Stopper® stiletto

MADE IN EU design by KD

IT il piccolo stiletto ha carattere: il design color argento opaco della colonnina è in perfetta combinazione con i nastri in diversa tonalità. i vari elementi si sposano in armoniose proporzioni. stiletto non è solo bello, anche il suo valore qualitativo è riconoscibile a prima vista. il freno a forza centrifuga assicura il rientro controllato del nastro e la chiusura di sicurezza si sgancia in caso di emergenza. la fuga d'ombra generata dalla base dona a stiletto un look snello e slanciato.

DE der kleine stiletto hats drauf: silbermattes design in kombination mit flotten gurtfarben. alles in einem ausgewogenen größenverhältnis. aber nicht nur dass er gut aussieht, auch seine inneren werte können sich sehen lassen. die fliehkraftbremse sorgt für kontrollierten gurteinzug und der sicherheitsverschluss öffnet sich von selbst im notfall. durch die schattenfuge der bodenplatte wirkt der stiletto optisch besonders leicht.

EN little stiletto got it all: silvermatt design in combination with cool webbing colours. all together in balanced proportions, but the stiletto is not only good-looking but convinces with other qualities: the centrifugal brake assures the controlled webbing pullback and the safety lock opens automatically in case of emergency. thanks to the shadow gap of the base plate the stiletto has a very lean look.



advantages

- ✓ look piacevole: design elegante e materiali di alta qualità
 ansprechender look: klares, elegantes design - hochwertige materialien
 appealing look: lean, elegant design - high-grade materials
- ✓ alta sicurezza: freno a forza centrifuga per rientro controllato del nastro
 hohe sicherheit: fliehkraftbremse für kontrollierten gurteinzug
 high safety: centrifugal brake for controlled webbing pullback
- ✓ design uniforme: clip del nastro in tinta con il nastro stesso
 einheitliches design: bandklemme farblich passend zum gurt
 consistent design: webbing clip and webbing in the same colour
- ✓ per emergenze: chiusura di sicurezza con sistema antipánico
 für den notfall: sicherheitsverschluss mit anti-panic inklusive
 in case of emergency: safety lock with anti-panic opener

A stiletto

1	SSL915ALSZ	stiletto alu with black ribbon, 1 pc	
2	SSL915ALGR	stiletto alu with grey ribbon, 1 pc	
3	SSL915ALRS	stiletto alu with red ribbon, 1 pc	

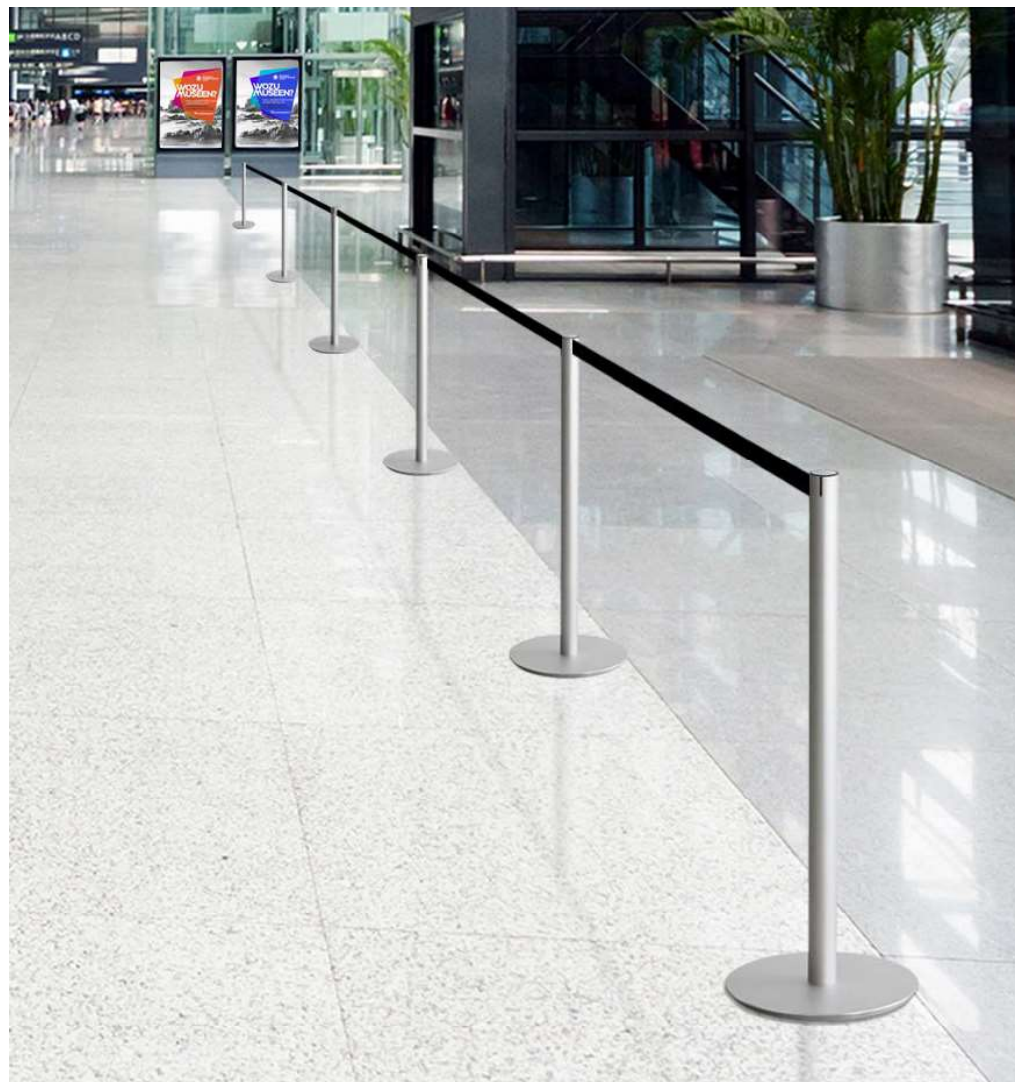

meccanismo con copertura anodizzata color argento

gurtgehäuse mit silbermatt eloxierter abdeckung

housing with silver matt anodized protection



base con fuga d'ombra e bordo smussato

basis mit schattenfuge und gefastem rand

base with shadow gap and chamfered edge



clip del nastro in tinta con il nastro stesso

bandklemme farblich passend zum gurt

webbing clip colour consistent with webbing

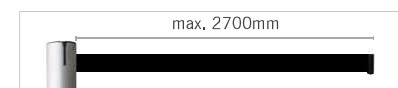



print

MADE IN EU design by KD



IT dirigete con stopper e approfittate di un nuovo spazio pubblicitario: il nastro è personalizzabile con serigrafia o stampa digitale. raccomandiamo la serigrafia per i loghi aziendali o scritte semplici; con la stampa digitale invece potremo realizzare per voi immagini in policromia e di maggiore impatto grafico. la stampa digitale, inoltre, permetterà di stampare a tutta superficie il colore della vostra azienda, per ulteriori dettagli non esitate a contattarci, saremo sempre a vostra completa disposizione.

DE zeigen sie mit stopper wo's langgeht und nutzen sie die möglichen zusätzlichen werbeflächen. der gurt kann mit siebdruck oder digital personalisiert werden. für einfache logos und schriftzüge empfehlen wir den siebdruck, während mit digitaldruck vielfarbigkeit und tolle effekte realisiert werden. sie können den gurt z.b. auch in der farbe ihres firmen corporates bedrucken lassen. dies empfiehlt sich auch bei geringen stückzahlen. fragen sie uns, wir beraten sie gerne.

EN show the way with stopper and use additional advertising space. the webbing can be customized with serigraphy or digital printing. for simple logos and words we recommend screen printing, while digital printing can make polychrome and sophisticated designs. you can also print the webbing to match your company's corporate colours. even small quantities are not a problem. ask us for more detailed information.



information



personalizzazione del nastro con stampa digitale o serigrafia. non esiti a contattarci, saremo sempre a sua completa disposizione!

personalisierung der gurte mit sieb- oder digitaldruck.

fragen sie uns, wir beraten sie gerne!

personalisation of the webbing with silkscreen or digital print. ask us, we will gladly provide you with all necessary details!

- free layout
- photo-quality
- colour-fast



insert | inlay

MADE IN EU design by KD



IT utilizzate il vostro stopper per attirare l'attenzione: il tubo in policarbonato trasparente e antiurto diventa una superficie pubblicitaria aggiuntiva oppure un decorativo espositore per oggetti, togliete il meccanismo avvolginastro ed inserite nel tubo una stampa digitale o dei piccoli oggetti. grazie alla speciale struttura il contenuto del tubo si può cambiare a piacere ed in ogni momento. inoltre, l'effetto pubblicitario è ulteriormente accentuato grazie alla speciale base stopper, anch'essa personalizzabile a piacere e velocemente.

DE nutzen sie ihr stoppersystem als hingucker: der posten aus transparentem, schlagfestem polycarbonat wird zur zusätzlichen werbefläche oder einem dekorativem objektpräsentier. sie nehmen den gurtmechanismus ab und bestücken den posten mit einem druck oder kleinen objekten, durch die spezielle konstruktion lässt sich der inhalt schnell und einfach jederzeit austauschen. mit dem glassinsatz der basis steigern sie diesen marketing effekt noch: auch sie lässt sich jederzeit schnell und einfach mit print personalisieren.

EN make your stopper an eye catcher: the post made of transparent, shock-resistant polycarbonate becomes an additional advertising space or a stylish item display. just unscrew the webbing mechanism and fill the post with a print or small items, thanks to the particular design the content can be exchanged easily anytime. and with the special stopper base glass inset you can boost your marketing effect even more: customize the base with a print in no time at all.

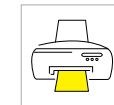
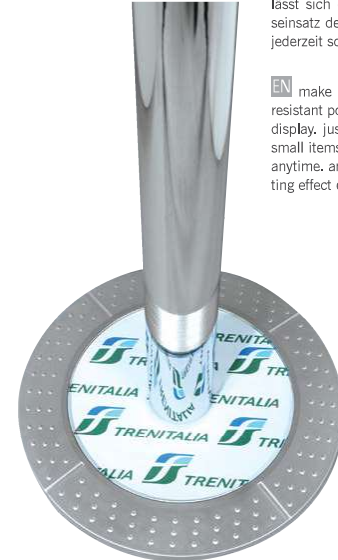

create e stampate il layout semplicemente con il pc
layout am eigenen pc gestalten und ausdrucken
design and print with your own workstation



Stopper® antipanic

MADE IN EU design by KD



IT stopper antipanic è il completamento ideale per la gamma di colonnine eliminacode stopper. L'adattatore può essere utilizzato e aggiunto a tutti i meccanismi con nastro della linea. La chiusura magnetica è strutturata in modo tale da svolgere perfettamente le due funzioni richieste: durante il normale utilizzo il nastro resta ben tensionato, in caso di una spinta o di pressione sul nastro, il gancio si stacca immediatamente. Ideale soprattutto per stopper installati presso entrate, uscite o passaggi con grande flusso di pubblico, stopper antipanic è un must tecnologico e di sicurezza che non si può trascurare.

DE stopper antipanic ist die perfekte ergänzung für ihr stopper personleitsystem, der adapter kann jederzeit an alle stopper gurtkassetten angebracht werden. sein magnetverschluss ist so eingestellt, dass der gurt bei normalem betrieb sicher hält, bei entsprechendem abruptem druck jedoch sofort öffnet. vor allem bei festinstallierten stoppern vor ausgängen ein sicherheitstechnisches muss.

EN stopper antipanic is the perfect supplement for your stopper crowd control. the adapter can be mounted anytime to all our stopper webbing houses, the magnetic lock will hold the webbing safely under normal conditions, but will open immediately under abrupt pressure. antipanic is ideal for permanently installed stopper systems in front of exits, the antipanic adapter is a must to ensure public safety.



abs di colore nero, con chiusura magnetica.
schwarzes abs kunststoff mit magnet.
black abs with magnet.



information

niente panico: la chiusura magnetica si rilascia in caso di emergenza

keine panik: magnet öffnet im notfall

no panic: the magnet opens in case of an emergency



attention

meccanismo avvolginastro e nastro non inclusi, ulteriori informazioni su pagina 251.

gehäuse und gurt nicht inclusive, mehr informationen auf seite 251

housing and webbing not included, for more information see page 251

A stopper antipanic

1	STAP70SZ	adapter antipanic black, 1pc
---	----------	------------------------------



Stopper® wall

MADE IN EU design by KD



IT attacco a parete stopper: con l'attacco a parete avete a disposizione lo stesso raccordo a 4 direzioni delle colonnine a terra, ma non solo: il nastro infatti potrà fuoriuscire dall'attacco a parete sia sul fronte che di lato, ma anche dalla quarta via d'uscita, posteriore, nel caso in cui l'attacco a parete venisse montato in un luogo nascosto dietro ad un muro o ad un mobile, per esempio, l'attacco a parete insomma si fa notare solo se serve e nel caso in cui debba essere utilizzato, altrimenti rimarrà nascosto. completate il fissaggio del nastro montando alla parete l'attacco „stopper clip“ oppure agganciatelo al meccanismo di un'altra colonnina stopper.

DE ohne pfosten und basis: mit der wandhalterung steht ihnen auch das komplette 4-wege system von stopper zur verfügung, nicht nur die auszüge parallel und rechtwinklig zur montagefläche, sondern auch der 4. auszug rückseitig, den 4. auszug setzen sie dann ein, wenn sie die wandhalterung verdeckt montieren, hinter trockenbauwänden oder in möbeln installiert, macht sich ihr stopper dann nur im bedarfsfall bemerkbar. alle stopper-gurtkassetten passen in den wandhalter, als gegenstück zum einhängen des gurt, wandmontieren sie einfach den stopper clip, je nach räumlicher gegebenheit können sie natürlich auch an ein stopper pfosten-element anschliessen.

EN no post, no base: use the 4-way system of stopper also with wall mount, you can use the pullouts forward or parallel to the wall and the 4th direction backwards as well. this direction is used when you mount the supports hidden behind walls or integrated in furniture, as counterpart just wallmount the stopper clip, depending on the location you can, of course, also connect the webbing to another stopper post.



attacco a parete in croma lucido STWH130CM oppure in argento satinato STWH130AR, comprensivo di viti e tasselli per il montaggio.

stopper wandhalterung hochglanz verchromt STWH130CM oder silbermatt veredelt STWH130AR, inkl. schrauben und dübel für die wandmontage.

stopper wall support high-gloss chrome-plated STWH130CM or silver satinated STWH130AR, incl. screws and dowels for mounting.



stopper clip a muro in ABS grigio luce e ABS nero, vite e tassello per il montaggio a muro inclusi.

stopper wandclip in ABS lichtgrau und ABS schwarz inkl. schraube und dübel für die wandmontage.

stopper wallclip synthetic light grey and black, screw and dowel for wallmounting included.

attention

meccanismo avvolginastro e nastro non inclusi, ulteriori informazioni su pagina 301.

gehäuse und gurt nicht inclusive, mehr informationen auf seite 301.

housing and webbing not included, for more information see page 301.

A stopper wall

1	STWH130CM	stopper wall mount chrome-plated, 1pc
2	STWH130AR	stopper wall mount silver coated, 1pc
3	STWC90LG	stopper wallclip, ABS light gray, 1pc
4	STWC90SZ	stopper wallclip, ABS black, 1pc





Stopper accessories

MADE IN EU design by KD



4

stopquick



IT moltiplicate le funzioni del vostro sistema stopper, attacco a parete o tex, avvitare il sostegno universale ad U alla colonnina, scegliere ed inserire i supporti in acrilico nel sostegno ad U, tutti i supporti sono intercambiabili, il nostro consiglio: tali supporti in acrilico sono compatibili anche con flip e flippy, della linea zip.

DE erweitern sie mit den stopper accessoires stopper, stopper wandhalter oder tex, universal haltebügel stophold einfach aufgeschrauben, das passende acrylglas-display auswählen und einschieben. displays können jederzeit gewechselt werden. unser tip: alle displays passen auch zu flip und flippy der zip serie.

EN upgrade your stopper, stopper wall or tex system with the accessories. stophold support is simply screwed on all stopper versions, then choose the needed acrylic glass display and insert it into stophold. you can replace the displays anytime. our tip: all displays match also with the zip items flip and flippy.

information

avvitare stophold alla colonnina, scegliere ed inserire i supporti in acrilico nel sostegno ad U.

stophold einfach aufgeschrauben, das passende acrylglas-display auswählen und einschieben.

stophold support is simply screwed on all stopper versions, choose the needed acrylic glass display and insert it into stophold.



A stopper accessories

1	STH250230CM	stophold, 1pc
2	STB305240GL	stopbag, 1pc
3	STQ302240GL*	stopquick, 1pc
4	STF302240GL*	stopfix, 1pc

* fino ad esaurimento scorta | solange vorrat reicht | while stock last



2 stopbag

1 stophold



stophold sostegno cromo lucido, 230mmx-250mm (hxb).

stophold haltebügel, hochglanz- verchromt, 230mmx250mm (hxb).

stophold display holder, high-gloss chrome-plated, 230mmx250mm (hxb).

stopbag tasca portadepiant in acrilico color vetro, spessore 3mm, per formato DIN A4, inclinata di circa 30°, adatta per circa 200 fogli singoli.

stopbag acrylglas prospekttasche, 3mm, DIN A4 format, 30° neigung für ca. 200 einzelblattprospekte.

stopbag glassgreen acrylic brochure pocket, thickness 3mm for DIN A4 format, inclination 30° for approx. 200 single sheet brochures.



stopquick portaposter a tasca in acrilico color vetro, spessore 3mm, per formato DIN A4, con calamita per la chiusura, verticale, mono e bifacciale.

stopquick acrylglas-posterhalter 3mm, für ein einzelblatt DIN A4 format, ein- und beidseitige ansicht, öffnung mit magnetverschluss.

stopquick glassgreen acrylic poster holder, thickness 3mm, for one single sheet in DIN A4 format, vertical, front and rear view, magnetic lock.



stopfix pannello singolo per informazioni in acrilico color vetro, spessore 3mm, per formato DIN A4, mono e bifacciale, per cartelli di direzione e di indicazione.

acrylglas-infoschild stopfix im DIN A4 format, stehend, ein- und beidseitige ansicht, für individuelle gestaltung und beschriftung.

glass-green acrylic information sign stopfix in DIN A4 format, vertical, front and rear view, for individual design and print.



Stopper[®] tex

MADE IN EU design by KD



IT stopper tex è la variante classica del sistema guidafilee eliminacorde, grazie all'utilizzo di materiali nobili e ad una lavorazione di qualità, lo stopper tex è particolarmente indicato per gli ambienti eleganti di ricevimento, come le hall di un albergo, per le mostre e le rappresentazioni in musei o teatri o anche per dare un tocco di raffinata eleganza allo showroom. stopper tex mette a vostra disposizione la possibilità di agganciare fino a 8 corde ad una sola colonnina. i morsetti, eleganti e funzionali, rendono l'aggancio facile e sicuro, grazie al meccanismo di sicurezza dei morsetti non è possibile che si sgancino inavvertitamente. ogni stopper tex è dotato, nella parte superiore, di un foro filettato M8 per l'utilizzo degli accessori in programma

DE stopper tex ist die klassische variante des personelleitensystems. mit den edlen materialien in hochqualitativer verarbeitung empfiehlt sich stopper tex vor allem für das elegante ambiente im empfangsbereich, in hotelfoyers, für besondere ausstellungsstücke in museen oder im showroom. der pfosten bietet acht möglichkeiten die seile einzuhängen. formschöne clips rasten einfach und sicher ein. durch den karabiner-effekt wird unbeabsichtigtes lösen verhindert. alle stopper tex haben ein M8 gewinde passend für alle elemente des stopper zubehörprogramms.

EN stopper tex is the classic way of crowd control. high class material with high quality finish characterises stopper tex. especially for the elegant ambience in reception areas or hotel foyers as well as for exceptional exhibits in museums or showrooms stopper tex is recommended. the post has eight openings to hang in the rope. shapely clips make the attaching easy and safe. the karabiner-like closing prevents from unintended opening or sliding out. all stopper tex have a M8 thread suitable for all elements of the stopper accessories assortment.



information

tubo alluminio anodizzato, attacco corda ottone cromo lucido e argento satinato base sistema modulare con piastra ferro, copertura in abs grigio chiaro, inserto alluminio anodizzato color argento, ø240mm

pfosten eloxiertes aluminium, seilhalter messing verchromt und versilbert, modulare basis ø240mm mit grundplatte in eisen, abs-abdeckung lichtgrau, dekoreinsatz silber eloxiertes aluminium.

post anodized aluminium, cord support brass silver and chrome-plated base modular base ø240mm with iron plate, abs cover light grey, silver anodized aluminium inset

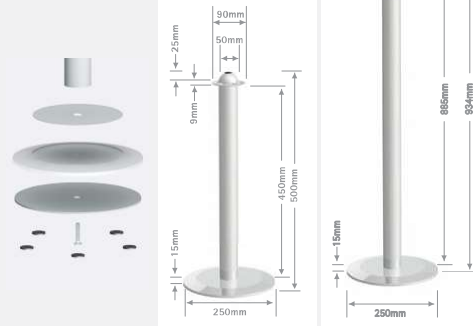

Stopper[®] tex alu

MADE IN EU design by KD



IT tex alu rappresenta una versione economica e semplice, mantenendo tutti i vantaggi del sistema tex. l'alluminio di alta qualità del tubo non solo lo rende elegante ma anche resistente nel tempo, grazie allo speciale design la base del vostro tex alu è stabile e allo stesso tempo robusta. il supporto, comprensivo di 8 buchi per il cordone, e la semisfera sono rispettivamente in ottone color cromo lucido ed argento satinato, nelle pagine successive potrete trovare tutte le corde combinabili. anche stopper tex è comprensivo del filetto che permette di avvitare tutti gli accessori stopper.

DE tex alu bietet als ökonomische, schlanke version alle vorteile des tex-systems. das hochwertige silber eloxierte aluminium des pfostens sieht gut aus und ist dabei langlebig. durch das spezielle design der basis ist ihr tex alu stabil und widerstandsfähig zugleich. 8-loch seilhalter und halbkugel sind aus verchromtem bzw. versilbertem messing. die passenden seile finden sie auf den folgenden seiten, auch der tex alu ist mit einem passenden gewinde versehen, in das die stopper accessoires einfach eingeschraubt werden.

EN tex alu is a leaner and more economic version with all the advantages of the tex-system. the high-grade silver anodized aluminium makes the post not only look good but also durable. the special design of the base makes your tex alu stable and sturdy at the same time. the 8-hole cord support and the semisphere are made of chrome- resp. silver-plated brass. appropriate cords you'll find on the following pages. tex alu also comes with a thread matching for all stopper accessories.



A	tex alu	
1	TXAL	set stopper tex alu, 1pc
2	TXALMI	set stopper tex alu mini, 1pc



1 set stopper tex chrome-plated



2 set stopper tex brass-plated

set stopper tex: cromo lucido
set stopper tex: verchromt
set stopper tex: chrome-plated

set stopper tex: ottonato lucido
set stopper tex: vermessingt
set stopper tex: brass-plated

information



Stopper[®] tex

MADE IN EU design by KD

IT elegante, raffinato e di qualità: ecco come si presenta stopper tex. la base e il tubo sono realizzati in acciaio polito. la testina superiore è invece realizzata in ottone. tutte le parti che compongono stopper tex sono rifinite con una cromatura lucida di protezione, potete scegliere tra la versione in cromo lucido e la versione in color ottone lucido, stopper tex è alto 940mm e poggia in modo sicuro su una base del diametro di 250mm.

DE formschön und hochwertig präsentiert sich stopper tex. basis und pfosten sind aus poliertem stahl. das kopfteil aus messing-drehteilen. alle teile sind hochglanz veredelt. wählen sie zwischen der farbausführung in messing oder chrom. stopper tex ist 940mm hoch und steht sicher auf der basis mit 250mm durchmesser.

EN stopper tex introduces itself with elegance and high-grade materials. base and post are made of polished steel. the sphere is composed of turned brass pieces. all parts are high-gloss finished. choose between brass- or chrome-plated. stopper tex is 940mm high and stands firmly on the base with 250mm diameter.

A tex

1	TXCM	set stopper tex chrome-plated, 1pc
2	TXOT	set stopper tex brass-plated, 1pc



1 set stopper tex double chrome-plated

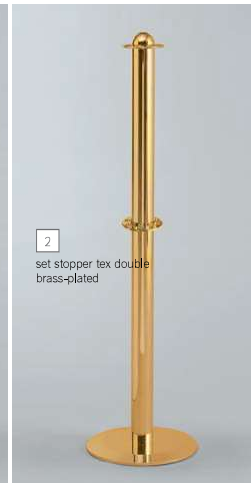

2 set stopper tex double brass-plated

tubo tex: cromo lucido con doppio aggancio per corde
pfosten tex: verchromt mit doppei-seilhalter
tex post: chrome-plated with double cord support

tubo tex: cromo lucido con doppio aggancio per corde
pfosten tex: verchromt mit doppei-seilhalter
tex post: chrome-plated with double cord support

Stopper[®] tex double

MADE IN EU design by KD

IT grazie al doppio sistema di aggancio per le corde non raddoppiate solo la sicurezza ma anche l'effetto di stopper tex. il secondo aggancio è mobile e si può posizionare a piacere sulla colonnina, all'altezza desiderata. i due agganci sono compatibili con tutte le corde della nostra gamma, che sia con la classica corda in polipropilene o con il robusto cavo di acciaio, il nostro assortimento tex offre la soluzione giusta per ogni ambiente.

DE verdoppeln sie nicht nur die sicherheit, sondern auch die wirkung mit dem zweifachen seilhalter-system. der zweite halter ist verschiebbar und wird einfach auf die gewünschte höhe eingestellt. beide halter sind kompatibel mit allen seilen aus unserem programm. ob seile aus edelstahl oder farbigem polypropylen, unser tex sortiment bietet das richtige für jedes ambiente.

EN duplicate not only the security but also the look with the double rope support, the second support can move along the post and is simply adjusted to the desired height. both supports match with all our ropes. the tex assortment offers you ropes made of stainless steel and coloured polypropylen going with every ambience.

A tex double

1	TX2CM	set stopper tex double chrome-plated, 1pc
2	TX2OT	set stopper tex double brass-plated, 1pc

Stopper®

tex cord

MADE IN EU design by KD

A



morsetto in cromo lucido con clip nichelata.
seilkappe hochglanz verchromt mit karabiner-clip, vernickelt.
rope connector chrome-plated with nickel-plated carabiner.



	lunghezza länge length				
1	1000mm	TEXSCMBL100	TEXSCMRS100	TEXSCMSW100	TEXSCMGR100
2	1500mm	TEXSCMBL150	TEXSCMRS150	TEXSCMSW150	TEXSCMGR150
3	2000mm *	TEXSCMBL200	TEXSCMRS200	TEXSCMSW200	TEXSCMGR200



morsetto in ottone lucido con clip nichelata.
seilkappe hochglanz vermessingt mit karabiner-clip, vernickelt.
rope connector brass-plated with nickel-plated carabiner.



	lunghezza länge length				
4	1000mm	TEXSOTBL100	TEXSOTRS100	TEXSOTSW100	TEXSOTGR100
5	1500mm	TEXSOTBL150	TEXSOTRS150	TEXSOTSW150	TEXSOTGR150
6	2000mm *	TEXSOTBL200	TEXSOTRS200	TEXSOTSW200	TEXSOTGR200

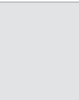

morsetto in cromo lucido con clip nichelata.
seilkappe hochglanz verchromt mit karabiner-clip, vernickelt.
rope connector chrome-plated with nickel-plated carabiner.



	lunghezza länge length	
7	1000mm	TEXSCMIX100
8	1500mm	TEXSCMIX150
9	2000mm *	TEXSCMIX200



10 TEXWHCM
gancio stopper tex per parete in cromo lucido conf. a 1 pz incl. viti e tasselli
stopper tex wandhalter verchromt packg. 1st inkl. schrauben und dübel
stopper tex wallclip chrome-plated package 1pc incl. screws and dowels

* questa lunghezza non è adatto per stopper tex | diese länge ist nicht für stopper tex geeignet | this length is not suitable for stopper tex

blu | blau | blue

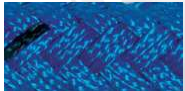

rosso | rot | red



nero | schwarz | black



grigio | grau | grey



stainless steel



IT Le corde in polipropilene vengono intrecciate appositamente per il nostro stopper tex. il materiale di cui sono composte non scolorisce ed è inoltre resistente a polvere e sporcizia. dalla nostra gamma potete scegliere 4 colori e 3 lunghezze standard. il morsetto è cromato lucido nelle finiture cromo e ottone. di particolare effetto è la nostra quinta variante, il cavo in acciaio inox. la clip vera e propria, nichelata, garantisce un sistema di chiusura che non può essere sganciato inavvertitamente.

DE speziell für stopper tex werden die seile aus polypropylen geflochten, das material ist farbecht sowie staub- und schmutzabweisend. sie können aus vier farben in jeweils drei standardlängen wählen. die seilkappe ist hochglanz vermessingt oder verchromt, der verschlusskarabiner in lackierter nickelausführung sorgt für einfache und sichere befestigung des seils.

EN exclusively for stopper tex the ropes are plaited in polypropylene, the material is colour fast as well as dust- and soil-resisting, the ropes come in four colours with three standard lengths. the rope connector is high-gloss chrome- or brass-plated. the rope is clipped safely and easily with the locking carabiner.



A tex cord

1	cord 1000mm (all colours), chrome-plated support	1pc
2	cord 1500mm (all colours), chrome-plated support	1pc
3	cord 2000mm (all colours), chrome-plated support	1pc
4	cord 1000mm (all colours), brass-plated support	1pc
5	cord 1500mm (all colours), brass-plated support	1pc
6	cord 2000mm (all colours), brass-plated support	1pc
7	cord 1000mm, stainless steel	1pc
8	cord 1500mm, stainless steel	1pc
9	cord 2000mm, stainless steel	1pc
10	TEXWHCM wallclip chrome	1pc

altre lunghezze disponibili a richiesta | weitere längen auf anfrage | other sizes on demand



stophold sostegno cromo lucido, 230mmx-250mm (hxb)

stophold haltebügel, hochglanz-verchromt, 230mmx250mm (hxb)

stophold display holder, high-gloss chrome-plated, 230mmx250mm (hxb)



stopbag tasca portadocumenti in acrilico color vetro, spessore 3mm, per formato DIN A4, inclinata di circa 30°, adatta per circa 200 fogli singoli.

stopbag acrylglass prospekttasche, 3mm, DIN A4 format, 30° neigung für ca. 200 einzelblattprospekte.

stopbag glassgreen acrylic brochure pocket, thickness 3mm for DIN A4 format, inclination 30° for approx. 200 single sheet brochures.



stopup portaposter a tasca in acrilico color vetro, spessore 3mm, per formato DIN A4, inclinato di 45°, inserimento del foglio laterale.

stopup acrylglass-posterhalter 3mm stark für ein einzelblatt im DIN A4 format, 45° neigung, seitlicher einschub.

stopup glassgreen acrylic poster holder, thickness 3mm, for one single sheet in DIN A4 format, inclination 45°, insertion sideways.



stopquick portaposter a tasca in acrilico color vetro, spessore 3mm, per formato DIN A4, con calamita per la chiusura, verticale, mono e bilaciale.

stopquick acrylglass-posterhalter 3mm, für ein einzelblatt DIN A4 format, ein- und beidseitige ansicht, öffnung mit magnetverschluss.

stopquick glassgreen acrylic poster holder, thickness 3mm, for one single sheet in DIN A4 format, vertical, front and rear view, magnetic lock.



stoppix A4 monofacciale e bifacciale: poster display privo di cornici, policarbonato trasparente.

stoppix A4 ein- und doppelseitig: rahmenloses posterdisplay, transparentes polycarbonat.

stoppix A4 single-sided, frameless poster display, transparent polycarbonate.



stopfix pannello singolo per informazioni in acrilico color vetro, spessore 3mm, per formato DIN A4, mono e bilaciale, per cartelli di direzione e di indicazione.

acrylglass-infoschild stopfix im DIN A4 format, stehend, ein- und beidseitige ansicht, für individuelle gestaltung und beschriftung.

glass-green acrylic information sign stopfix in DIN A4 format, vertical, front and rear view, for individual design and print.

tex accessories

MADE IN EU design by KD



IT con gli accessori della nostra gamma potete moltiplicare le funzioni del vostro sistema tex: informare, presentare o fare pubblicità non sono un problema. il sostegno universale ad U viene semplicemente avvitato sulla testina dello stopper tex, già dotate a foro filettato per questo utilizzo. i supporti in acrilico si inseriscono facilmente nel sostegno ad U e altrettanto facilmente possono essere cambiati in qualsiasi momento.

DE erweitern sie ihren tex: informieren, präsentieren oder bewerben ist mit den accessoires kein problem, der universal haltebügel stophold wird aufgeschraubt. stopper tex hat bereits das passende gewinde, das passende acrylglass-display auswählen und einschieben. die displays können sie jederzeit wechseln.

EN upgrade your tex: informing, presenting or advertising is no problem with the stopper elements. the holder stophold is screwed onto the post. choose the needed acrylic display and insert it into stophold, the displays are exchangeable anytime.

A tex accessories

1	STH250230CM	stophold, 1pc
2	STB305240GL	stopbag, 1pc
3	STU305240GL*	stopup, 1pc
4	STQ302240GL	stopquick, 1pc
5	STPQ1A4*	stoppix one side, 1pc
6	STF302240GL	stopfix, 1pc

* fino ad esaurimento scorte | solange vorrat reicht | while stock last

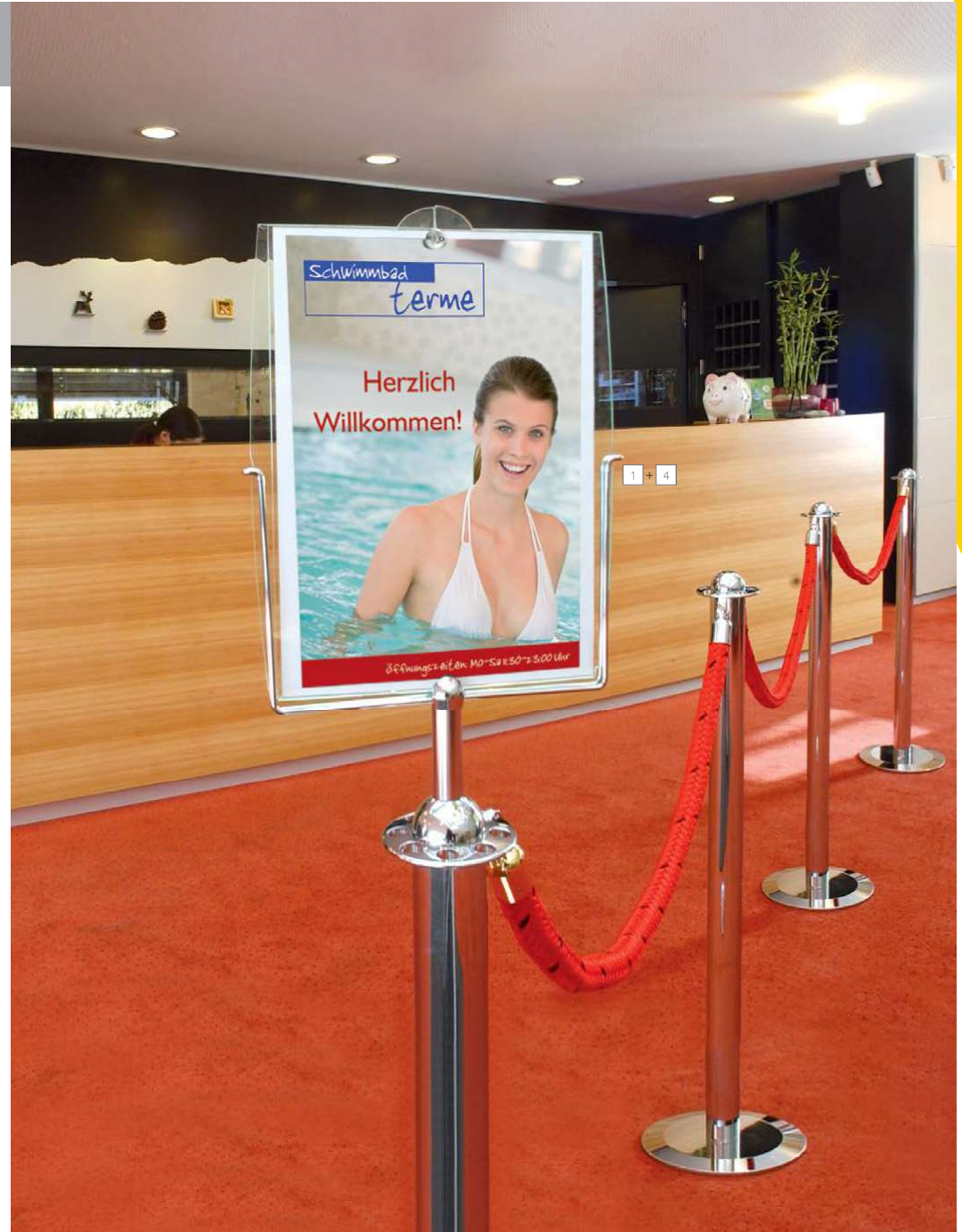

stopper

stopinfo soistes

MADE IN EU design by KD

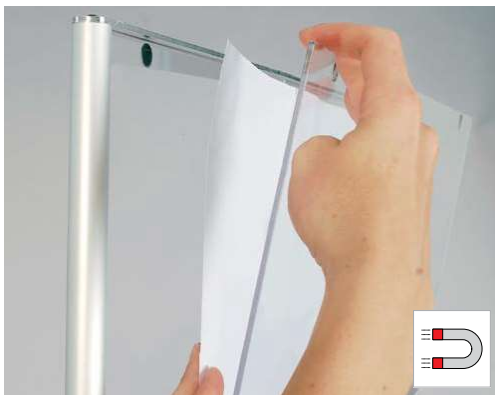

double side

IT display per informazioni stabile e sicuro, con tasca portaposter fronte retro in acrilico trasparente, grazie alla chiusura con calamita, il cambio delle informazioni è semplice e possibile in ogni momento. stopinfo diventa in un batter d'occhio multifunzionale e personalizzabile con l'aggiunta di semplici accessori: sui 2 ripiani in acrilico satinato, in formato A4, potrete esporre la vostra documentazione, mentre le barre laterali danno la possibilità di esporre oggetti da appendere, come borse e lanyards, ma anche catenelle o appendiabiti. gli accessori vengono consegnati con le istruzioni per il montaggio, così che sia sempre facile e veloce personalizzare il vostro stopinfo a piacere.

DE stabiles info-display mit doppelseitiger postertasche in transparentem acrylglas, durch die bewährte quick-verschluss-technik mit magnet ist der informativsaustausch jederzeit und schnell erledigt. multifunktional und individuell wird ihr stopinfo mit unserem zubehör: auf der ablage für 2 A4 aus satiniertem acryl präsentieren sie printinfo zum mitnehmen, während die display bars platz bieten für aufhängbares wie taschen, lanyards oder auch ketten und kleiderbügel. das zubehör wird mit dem erforderlichen montagezubehör geliefert, so können sie ihren stopinfo jederzeit nach- und aufrüsten.

EN stable information display with double-side poster pocket in transparent acrylic. thanks to the approved magnetic closing system, poster exchange is simple and easy at any time. make your stopinfo a multifunctional and individual display with our accessories: the tray for 2A4 formats is perfect for your take-away print information while the display bars showcase suspended items like bags, lanyards, clothes on hangers, necklaces etc. accessories come already with mounting material, thus you can upgrade your stopinfo anytime.

A stopinfo soistes

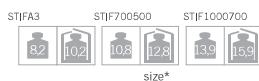

	size*
1 STIFA3	stopinfo A3, 1pc
2 STIF700500	stopinfo 700x500mm, 1pc
3 STIF1000700	stopinfo 1000x700mm, 1pc
4 SOTR2A4TR	tray 2 A4 V, 1pc
5 SODB300	display bar, set with 2pcs

* altezza x larghezza | höhe x breite | height x width



ripiano per 2 depliant in A4 verticale, acrilico satinato, inclinabile orizzontalmente e posizionabile liberamente su tutta la lunghezza del profilo.

ablage für 2 A4 aus satiniertem acrylglas, horizontal neigbar und stufenlos höhenverstellbar
made of silver anodized aluminium

satin acrylic tray for 2 A4 sized literature, these trays are adjustable horizontally and in height.

barre in alluminio anodizzato
stangen aus silber eloxiertem aluminium
bars made of silver anodized aluminium



information

tasca poster, alluminio anodizzato, base con protezione in abs cromato

- 1 297mm
- 2 500mm
- 3 700mm

acryl-postertasche, aluprofil eloxiert, verchromter abs-trittschutzring.

acrylic poster pocket, silver anodized aluminium extrusion, chrome-plated abs step-on-protection

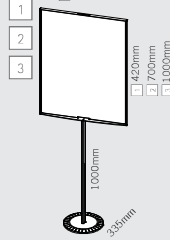

2 + 4
stopinfo 700x500mm + tray 2A4 V
price for this combination



ideas

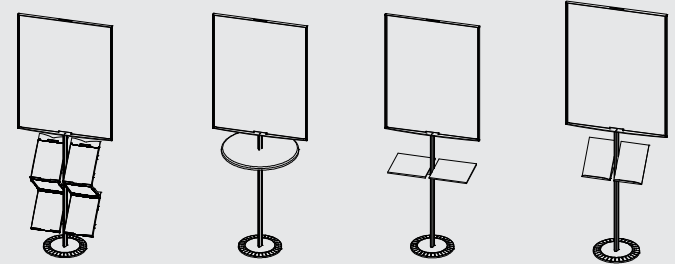

up-grade: possibili aggiunte come ripiani, tasche porta depliant o display per il proprio stopinfo personalizzato, contattateci pure per consigli e suggerimenti.

up-grade: mögliche add-on produkte wie ablagen, prospekttaschen oder info-display, für ihren persönlichen stopinfo, fragen sie uns, wir beraten sie gerne.

up-grade: possible add-on products like shelves, brochure pockets or displays for your personal stopinfo. please contact us for further details, it's our pleasure to assist you.



one side

maginfo slim soistes

MADE IN EU design by KD

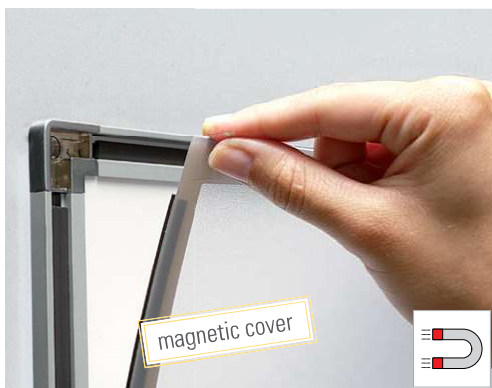

magnetic cover



IT maginfo slim è la perfetta combinazione di magndoor slim, cornice magnetica facilmente intercambiabile, e una struttura stabile e robusta in alluminio anodizzato, il cambio delle informazioni è pratico, facile e veloce: basta sollevare il foglio protettivo flessibile in policarbonato anti riflesso. maginfo slim può inoltre essere completato con un ripiano per 2 A4 in acrilico satinato.

DE maginfo slim kombiniert den schnellwechselrahmen magndoor slim und eine stabile soistes-struktur zum freistehenden bodendisplay. der informationswechsel ist schnell und unkompliziert: einfach die flexible coverfolie aus nicht reflektierendem polycarbonat abnehmen, optional kann ihr maginfo slim mit einer ablage für 2 A4 aus satiniertem acrylglas perfekt ergänzt werden.

EN maginfo slim combines the magndoor slim frame with a stable soistes structure to create a freestanding floor display. for information exchange simply swing open the flexible front cover made of non reflective polycarbonate. you can upgrade your maginfo slim with a transparent acrylic tray for two A4 formats.



ripiano per 2 depliant in A4 verticale, acrilico satinato, inclinabile orizzontalmente e posizionabile liberamente su tutta la lunghezza del profilo.

ablage für 2 A4 aus satiniertem acrylglas, horizontal und stufenlos höhenverstellbar made of silver anodized aluminium

satin acrylic tray for 2 A4 sized literature, these trays are adjustable horizontally and in height.

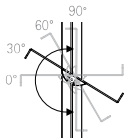

information

cornice magnetica maginfo slim, alluminio anodizzato color argento, base con rivestimento di protezione in abs.

schnellwechselrahmen maginfo slim, silber eloxiertes aluminium, abs-trittschutzring.

quick exchange frame maginfo slim, silver anodized aluminium, abs-step on protection ring.

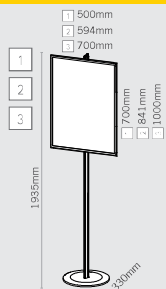

A maginfo slim soistes

		size*
1	SOMS700500	maginfo slim 700x500mm, 1pc
2	SOMSA1	maginfo slim A1, 1pc
3	SOMS1000700	maginfo slim 1000x700mm, 1pc
4	SOTR2A4TR	tray 2 A4 V, 1pc

* altezza x larghezza | höhe x breite | height x width



2° piano →
Ambulatorio
Camere
dal n.201 al n.220

1° piano →
Camere
dal n.101 al n.120

0° piano ←
Uffici Amministrativi
Direzione

1 maginfo slim 700x500mm

1 + 4 maginfo slim 700x500mm + tray 2A4 V price for this combination

order brochure shelf extra | tray 2 A4 V not included



2
set rondo table top mdf

rondo

MADE IN EU design by KD



IT grazie a rondo, dalla serie stopper, potete arredare i vostri ambienti con tavolini e punti di appoggio eleganti e funzionali. base con rivestimento di protezione in abs cromato; tavolini disponibili in vetro e in mdf verniciato color argento: usati in combinazione l'uno con l'altro, i due tavolini vi danno la possibilità di sfruttare una superficie personalizzabile. in aggiunta, potete rendere personalizzabile anche la base, grazie all'insero centrale in vetro da usare in combinazione con il rivestimento laterale di protezione. rondo è semplicissimo da montare, rendendosi così insostituibile per fiere, eventi, negozi, showroom e uffici.

DE mit den rondo tischen aus dem stopper programm mehrwert sichern: basis mit mattverchromten trittschutznng aus abs, die tischplatten sind in glas oder silberlackiertem mdf erhältlich. in der kombination beider ausföhrungen miteinander erhalten sie eine schnell personalisierbare werbefläche, dazu passt die ebenfalls schnell mit printinlay gestaltete basis mit glaseinsatz. rondo ist schnell aufgestellt und empfiehlt sich für messen, events, shop, showroom und office.

EN gain publicity space with the rondo tables: base with a satin chrome-plated step-on protection made of abs, the table tops are available in glass or silver-varnished mdf. with the combination of both table tops you get a quick customizable extra marketing space, in this version the base can also be customized with a print inlay in no time at all. rondo sets up quickly and is your perfect choice for fairs, events, shops, offices and showrooms.

information

base con rivestimento di protezione in abs cromato; tavolini disponibili in vetro e in mdf verniciato color argento

basis mit mattverchromten trittschutznng aus abs, die tischplatten sind in glas oder silberlackiertem mdf.

base with a satin chrome-plated step-on protection made of abs, the table tops are available in glass or silver-varnished mdf.

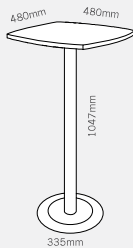

A rondo

1	STCRONDOVE*	set rondo table top glass, 1pc
2	STCRNDOMDF*	set rondo table top mdf, 1pc
3	STCRONDOVEMDF*	set rondo table top glass, 1pc

* fino ad esaurimento scorte | solange vorrat reicht | while stock last



1
cubo

cubo

MADE IN EU design by KD



conveniente per giochi a premi, elezioni, raccolta contatti su fiere, questionario per clienti o altre persone

praktisch für preisausschreiben, wahlen, kontakte auf messen sammeln, kunden- oder personenbefragung.

perfekt for competitions, elections, collection of business contacts on fairs, surveys of customers or in general

IT volete organizzare un gioco a premi, una votazione oppure semplicemente volete raccogliere i biglietti da visita dei vostri visitatori? la soluzione per tutto questo è cubo. il cubo di 300mm in acrilico satinato, con fessura nella parte superiore e porta richiudibile, è autoportante, e sorretto dalla stabile base con rivestimento di protezione in abs e dal tubo in alluminio anodizzato color argento satinato. nella confezione sono incluse 2 chiavi.

DE sie haben ein gewinnspiel, eine befragung, eine wahl zu organisieren oder wollen einfach die visitenkarten der besucher sammeln? alles kein problem mit cubo, der 300mm würfel aus satiniertem acrylglas, mit einwurf und verschließbarer tür ist freistehend auf einer stabilen basis mit abs-trittsschutznng und silber eloxiertem aluminiumpfosten montiert. zwei schlüssel sind im lieferumfang enthalten.

EN do you want to play a game with prizes, organise a vote or simply collect business cards from your visitors? the solution to all of this is cubo. the satin acrylic 300mm cube with a slot in the top and a lockable door, it is free standing with a stable base protected by abs, the post is in silver coloured anodised aluminium. 2 keys are included.

information

base con rivestimento di protezione in abs cromato; cubo di 300mm in acrilico satinato

basis mit mattverchromten trittschutznng aus abs, 300mm würfel aus satiniertem acrylglas

base with a satin chrome-plated step-on protection made of abs, satin acrylic 300mm cube

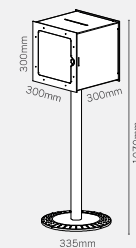

rispetto della privacy chiusura a chiave,

manipulationssicher verschliessbar.

privacy respected and tamper-proof



A cubo

1	CUBO250	cubo, 1pc
---	---------	-----------

